

# USER'S MANUAL

## TMT 800LS SLIDING GATE OPENER



Internal Transformer

# TABLE OF CONTENTS

Introduction & Recommendations .....	3
Areas of injury or entrapment .....	4
Technical Specifications .....	4
Kit Inclusions .....	5
Operator Parts Identification.....	5
Site Setup .....	6
Gate Forces.....	6
Automating Unlevel Gate .....	7
Anchoring Base Plate .....	8
Securing Motor .....	8
Manual Override .....	8
Mounting Racking .....	9
Mounting Limit Brackets .....	9
Power Cable Wiring .....	10
Backup battery wiring.....	10
Control Board Layout .....	11
Remote Tuning.. .....	12
System Learn.....	12
Factory Reset .....	13
Motor Current Auto Detection .....	13
LED Display .....	13
Auto Close Override .....	13
How to set the Parameters .....	14
Programmable Function Settings .....	14 - 17
Accessory Wiring .....	18
Service Schedule .....	22
Warranty.....	22 - 23



**Videos & more**



**Quick setup guide**

# INTRODUCTION & RECOMMENDATIONS

We strongly recommended using the services of an experienced gate installer to install your gate operator but if you intend installing the operator yourself, the manual must be read carefully before any installation begins.

While you have taken all reasonable steps to ensure that your gate operator is safe to install and use, it must be noted that your gate is a heavy moving piece of equipment and can cause serious damage or injury if it strikes an object or person. Your gate operator has a built in electronic collision sensing which will make the gate stop and reopen if it strikes an object. This does mean however, that the gate will actually strike the object before it stops. It is because of this that we strongly recommended that 'Safety Beams' are installed to reduce the risk of the gate striking an object. The installation of beams does not guarantee that the moving gate will not strike an object in it's path.

## Check the following items before installing the operator:

- That the rail is level – the gate must not move on its own at any stage.
- That the wheels are turning freely and are not jammed.
- That the gate is not bent or bowed in any way.
- That the rail has sufficient end stops so that the gate can never run off the end of the rail.
- That the gate setup is constructed in such a way that the gate can not fall over.
- That the top rollers are turning freely and are not jammed.
- That the gate does not jam in the catch bracket when closing or opening.
- The gate must not exceed the maximum number of operations stated in the specifications.
- Extreme care should be taken when automating a gate that is fully cladded, as wind resistance can cause the gate to not close properly.

Only when all the above points are satisfactory should you go ahead with installing the gate operator. Remember, if a gate causes damage or injury the installer of the equipment may be held liable.



## WE RECOMMEND A QUALIFIED ELECTRICIAN FOR WIRING UP MAINS POWER

- Electrical shock can occur while installing this equipment
- Injury or death by electrocution may lead to law suits against the installer/homeowner.
- All wiring should be run in conduit.
- Do not open, tamper or modify any of the electronic components of this equipment in any way.
- Do not attempt to repair the equipment, this should only be done by a qualified technician.
- We will not be held liable for any accident / incident resulting in damage, injury or death ensuing from the incorrect installation of the automatic gate operator.
- Although these operators have built-in collision sensing, substantial damage can still occur. For this reason 'Safety Beams' should be used on all installations.
- Do not allow children to play near or with any gate, gate operator or remote control.
- It is the responsibility of the installer to ensure that the gate is in good working condition before automating the gate.
- We cannot be held responsible for a gate bumping either of the ends stops if it runs on a slope.
- Do not operate the gate unless within direct sight of the gate.
- A gate is a heavy piece of equipment and injury, even death, may occur due to incorrect installation or operation of the equipment. There are a number of areas that may cause entrapment which could lead to injury.

## AREAS WHERE INJURY OR ENTRAPMENT CAN OCCUR

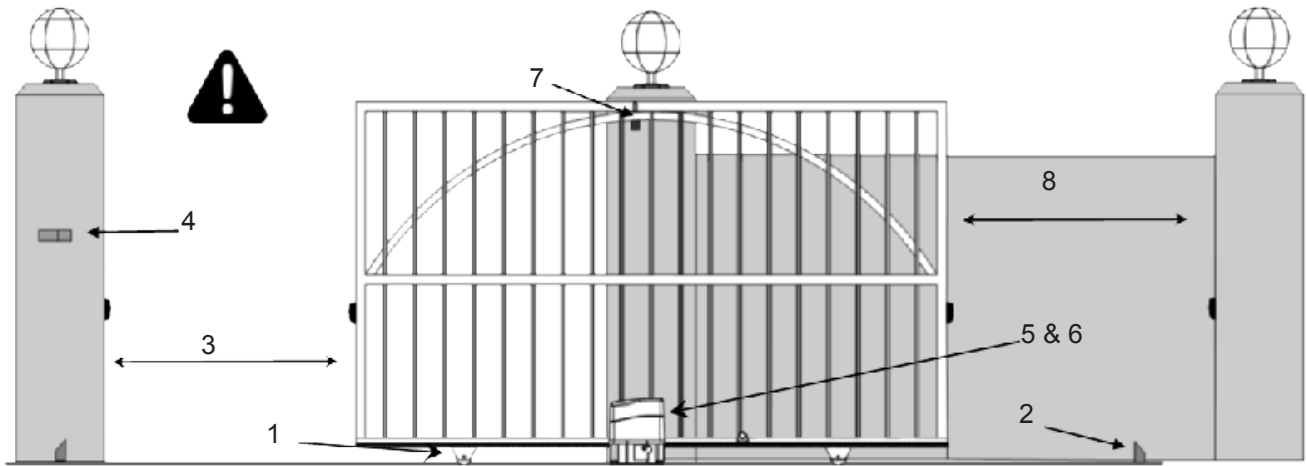

- |  |   |
|--|---|
| 1. Gate Wheels (Pets at risk when lying at the gate) | 5. Pinion Gear                          |
| 2. Between the gate & the end stop                   | 6. Between the gate operator & the gate |
| 3. The gate, during the closing cycle                | 7. Gate Rollers                         |
| 4. Between the gate & the catch bracket              | 8. The gate during opening cycle        |

## TECHNICAL SPECIFICATIONS

Thrust	8000N
Motor RPM	3600RPM
Wattage	144W
Voltage	24Vdc
Current	6A
Max. gate weight	800kg
Max. gate length	8mtrs
Duty cycle	70%
Manoeuvre speed	16m/min
Operating temperature	-20degC + 50degC
Max gate weight	800kgs - level ground

\* This technical data is simply indicative

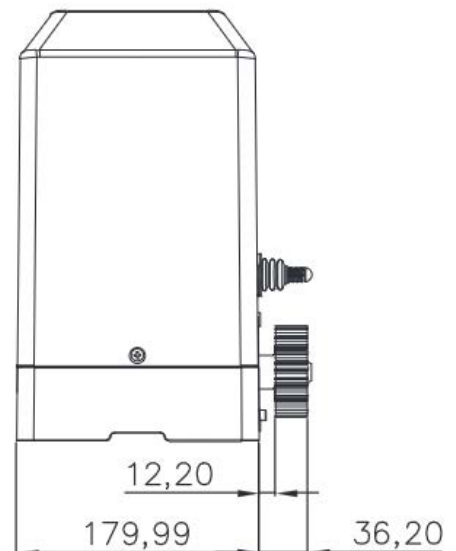
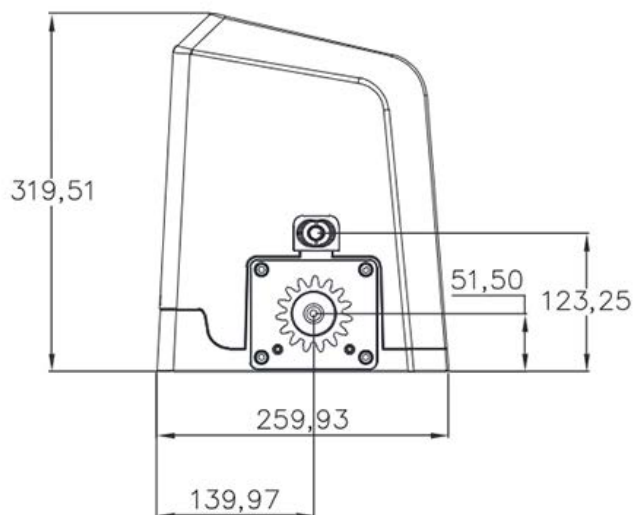

## KIT INCLUSIONS



Motor & Base Plate



4 x racking



2 x Release keys



2 x Remotes

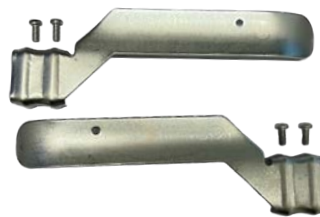

2 x limit brackets with screws



4 x Bolts and washers

## OPERATOR PARTS IDENTIFICATION

- a. Gear Cog
- b. Limit switch device
- c. 24Vdc motor
- d. Backup batteries (1.4ah optional)

- e. Release device
- f. Control panel under the cover
- g. Cover of the control panel
- h. Internal transformer

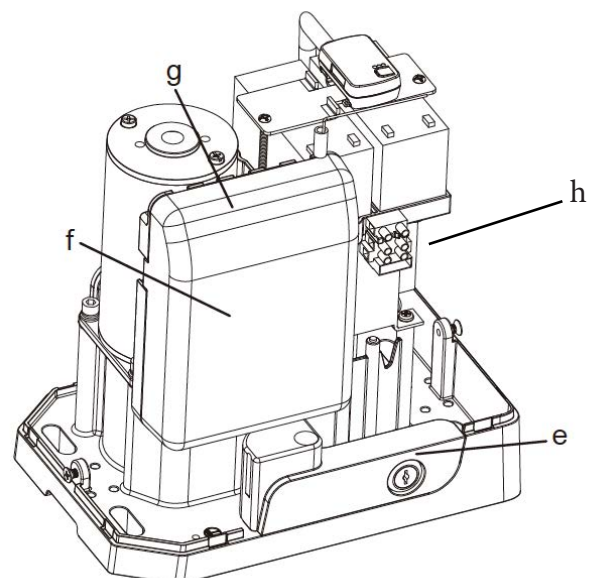
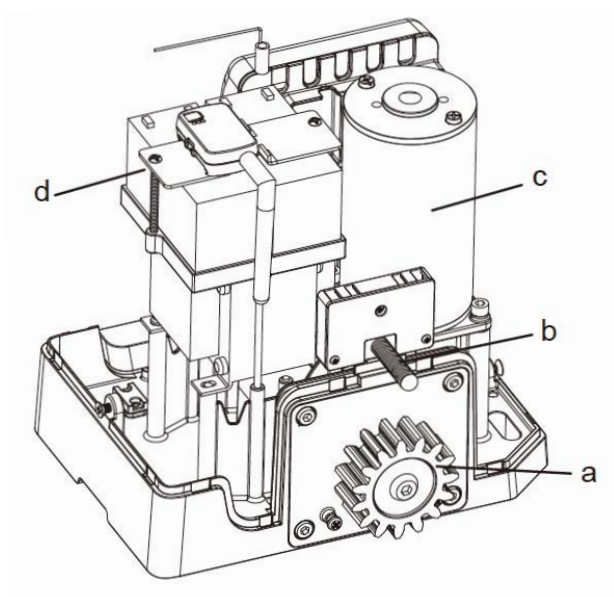

## SITE SETUP

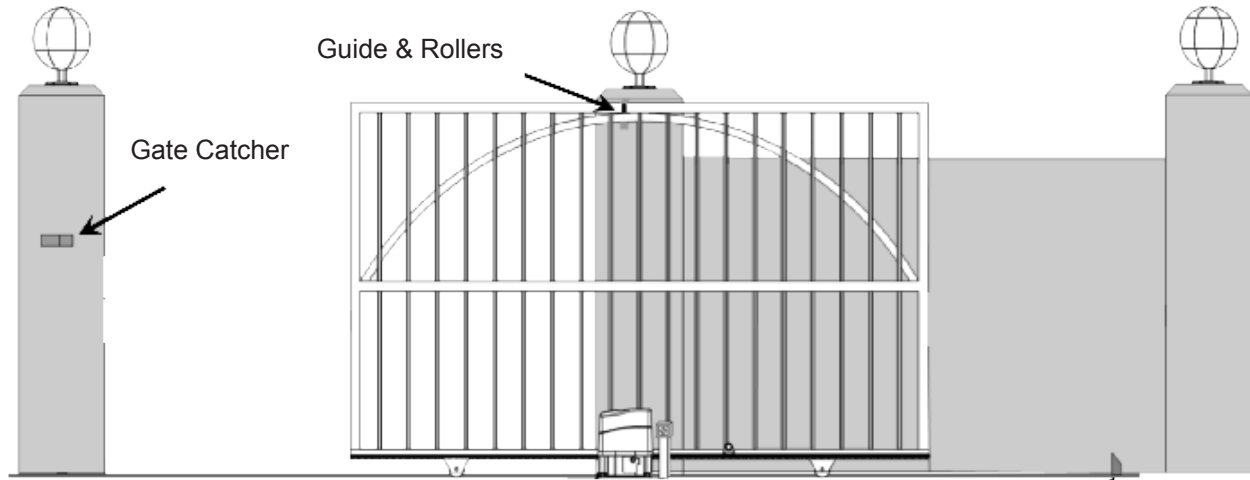

Important - the gate MUST have permanent end stops in both the closed and open positions to prevent the gate running off the track in the even of a failure

Gate Stop

## GATE PULL AND RUNNING FORCES

The gate Pull and Running Forces must be measured before installing the operator. Should the measured forces exceed those in the table below, then the operator must not be installed. It may be possible to reduce these forces by carrying out maintenance on the gate & rail but if not, then the operator must not be installed. These forces can be measured using a fishing or luggage scale (see figure alongside).

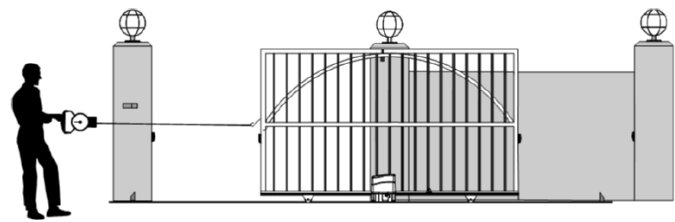

**Pull Force:** place the gate in the fully open/closed position and pull on the scale until the gate starts moving. The value showing on the scale at the point that the gate starts moving is the Start up Force kgf.

**Running Force:** this is the maximum value read while the gate is moving before coming to the fully open or closed position.

Maximum Gate Mass	800kg
Maximum Startup Force	28kgf
Maximum Running Force	18kgf

\*\* Weights above are for level ground

Gate must not exceed 12kg running force if not on level ground

## AUTOMATING UNLEVEL GATE

We do not recommend automating a gate which is not level. Failure to level the gate will put undue stress on the operator and the gate may bump the end stops. Furthermore, if the operator is in manual override mode, the gate may run freely down the slope and present a safety risk.

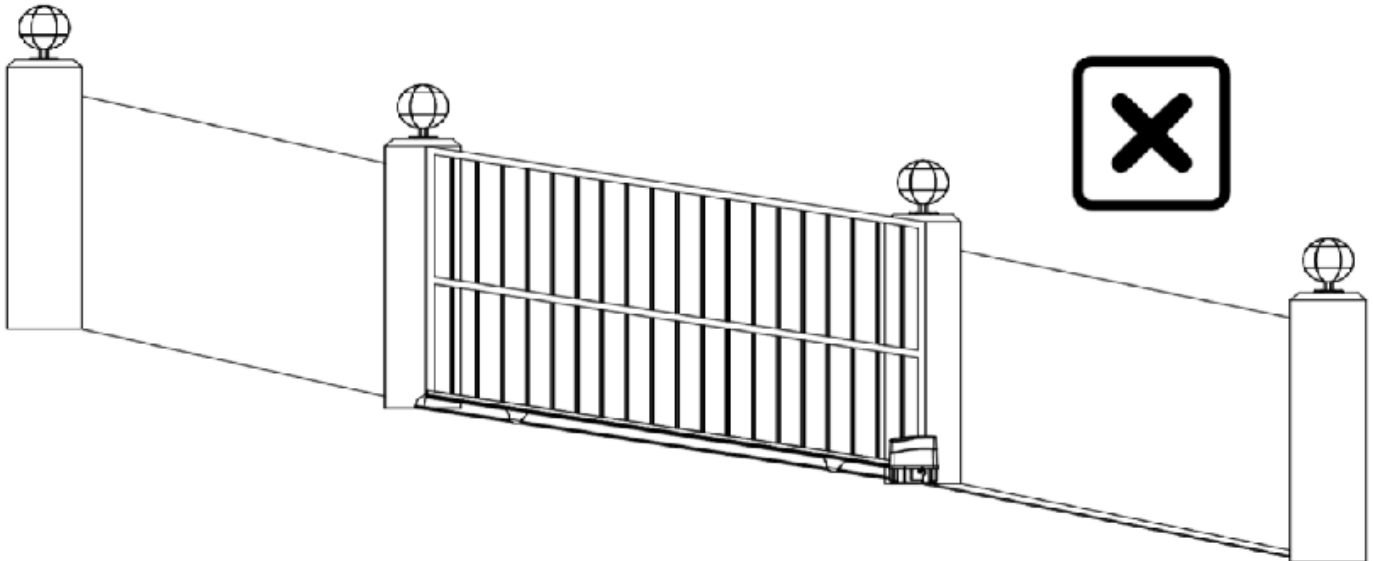

The gate should always be level. This can be achieved by leveling the track using supports or spacers.

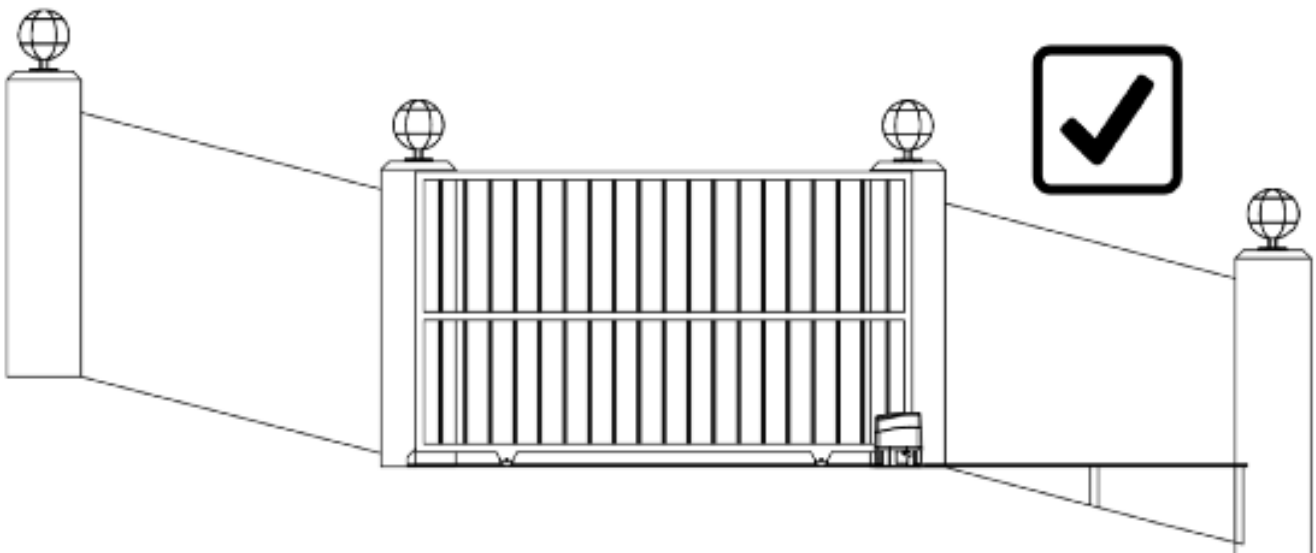

## ANCHORING THE BASE PLATE

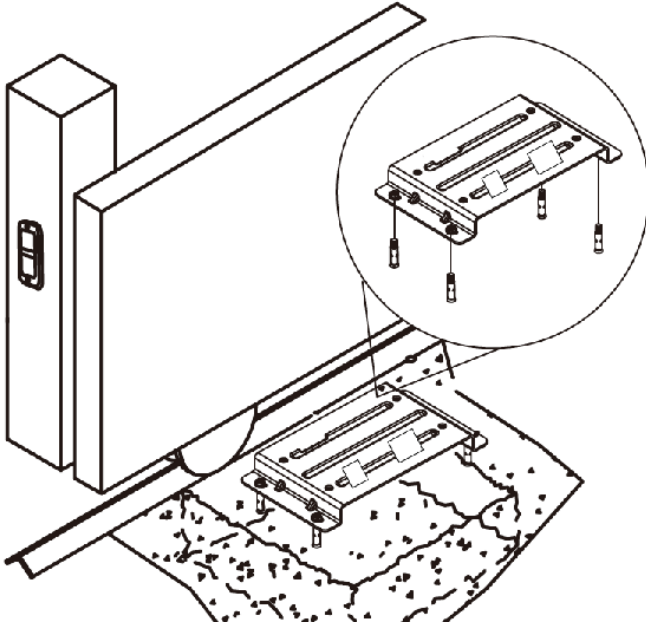

1. Lay a concrete slab 400mm x 400mm x 200mm. Dig a hole and place the conduit in the correct position. Fill the hole with concrete and allow to set. If you're not using conduit through the slab you can use the side outlets on the motor for the power cable.
2. Place the base plate on the concrete slab and if using the conduit, feed the conduit through the cable inlet of the base plate.
3. Keep a 60mm distance between the edge of the base plate and the gate frame.
4. Attach the base plate to the slab, using the 4 bolts supplied or other fixings.



**Note: the 60mm distance is using BMGi's racking which is 40mm wide**

## SECURE THE MOTOR TO THE BASE PLATE

Secure the motor to the base plate using the 4 screw holes as shown.

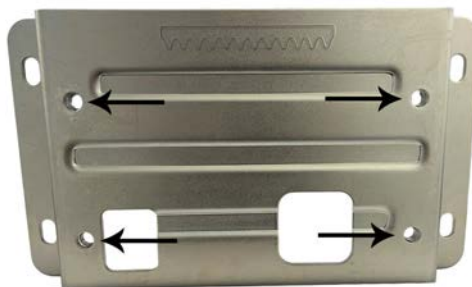
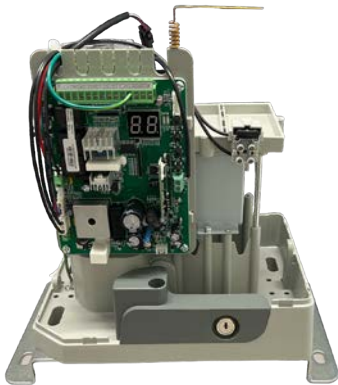

## PLACING THE MOTOR IN MANUAL OVERRIDE

When power has failed or you need to manually slide the gate open.

1. insert key
2. turn key clockwise to unlock device
3. pull the release bar





## MOUNTING THE RACK ON THE GATE

There must be a 2-3mm gap clearance between the mounted rack and the cog

1. Start with the gate in the open position, place the first piece of rack on the cog making sure you have the 2-3mm gap between the rack and cog.
2. Fasten the rack to the gate with the self drilling TEK screws through the slots in the rack.
3. To attach additional rack, slide the gate along and repeat with the above procedure until all the racking has been installed.

The racking must run the full length of the bottom gate rail including the tail.

Now slide the gate back and forth making sure the gate isn't catching or binding on anything



Watch Video

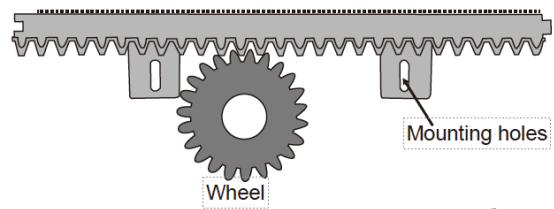
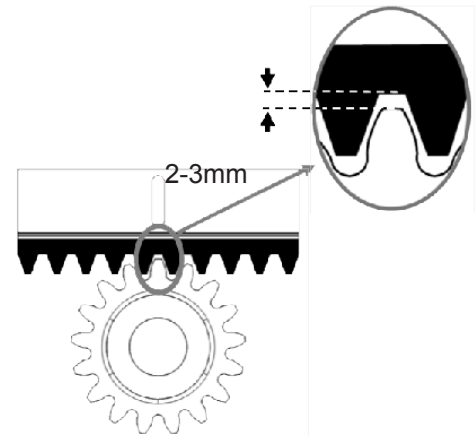

## MOUNTING THE LIMIT BRACKETS

Make sure your motor is in manual mode.

Open the gate until it hits the ground stop, now pull the gate back 40mm and install the limit bracket onto the racking, slide the gate bracket along until it just hits the spring, now screw the limit bracket to the racking.

Ensure the limit bracket level.

Slide the gate into the closed position till it hits the catcher stop, pull the gate back 40mm and install the limit bracket onto the racking, slide the bracket along until it just hits the spring and screw it to the rack, ensure the limit bracket is level.

**Note:** limits may require small adjustments after the gate has performed its system learn

Once the sysetm learn has been performed, operate the gate to open/close and ensure the gate doesn't touch the physical end stop. A 20mm gap is preferred.

Limit Bracket



Watch Video



# POWER CABLE WIRING

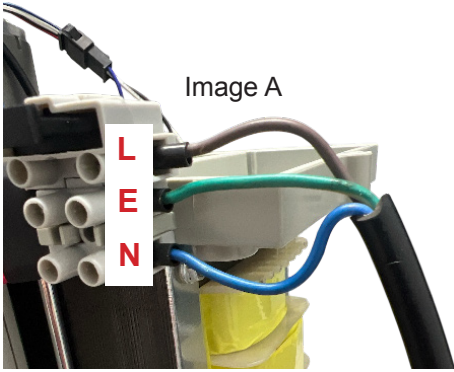

Secure the power cable through the baseplate or through the side outlets as shown in image C.

Now bring the cable through one of the (2) inlets. Secure the wire through the cable locking tab as shown in image B. This cable MUST be secured to prevent cable dislodgement.

Ensure your power cable is wired correctly as shown in image A  
L=Live E=Earth N=Neutral

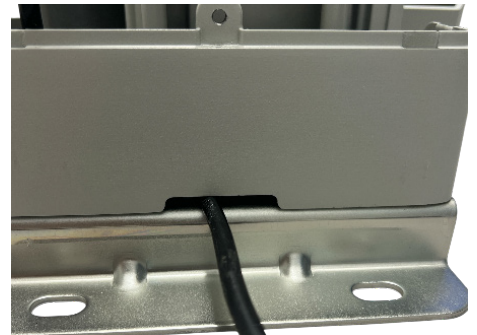

Image C

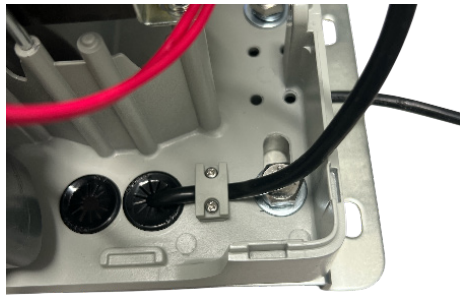
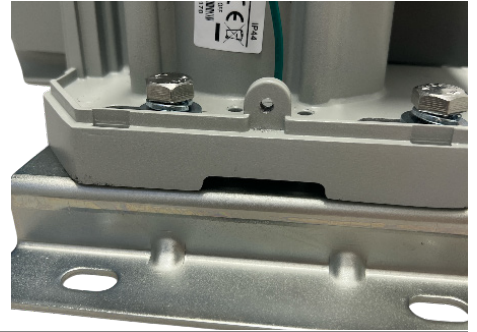

Image B



# OPTIONAL BACKUP BATTERY WIRING

The backup battery is optional and can be added at anytime. BMGi does not carry the battery size required.

Parts required:

- 2 x 12volt 1.4 amp hr batteries
- 1 x loop wire with battery connectors
- 1 x red power cable with battery connector
- 1 x black power cable with battery connector

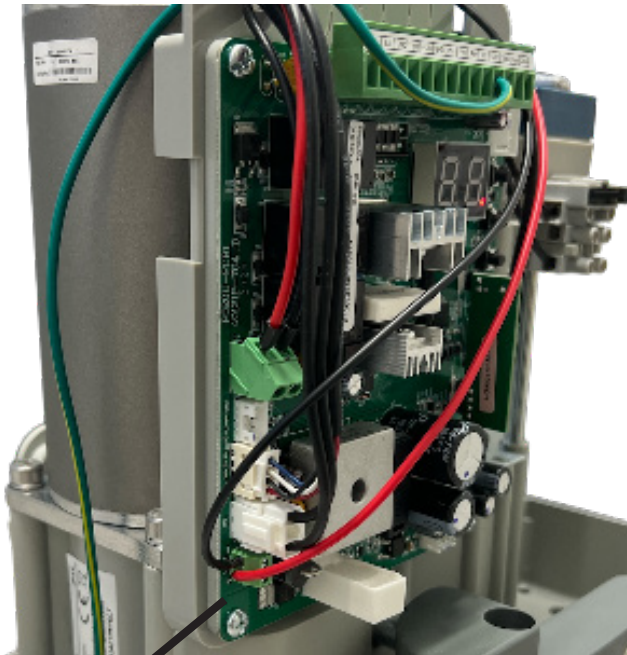

Black negative wire and red positive wire connected to battery terminal on main board

Ensure polarity is correct.  
If wired incorrectly, damage will occur to the board and warranty will be void.

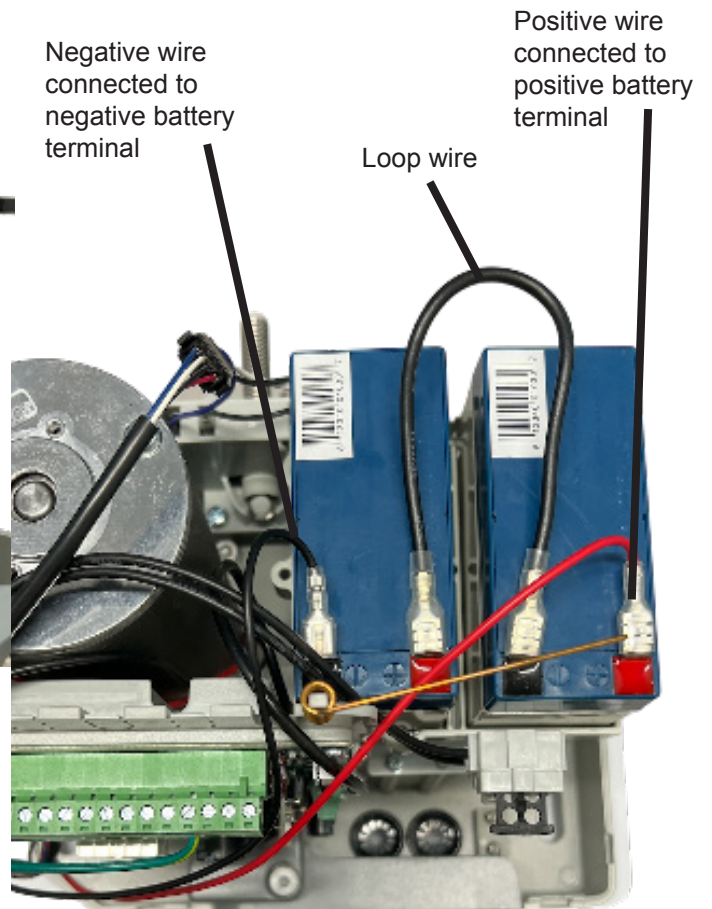

# CONTROL BOARD

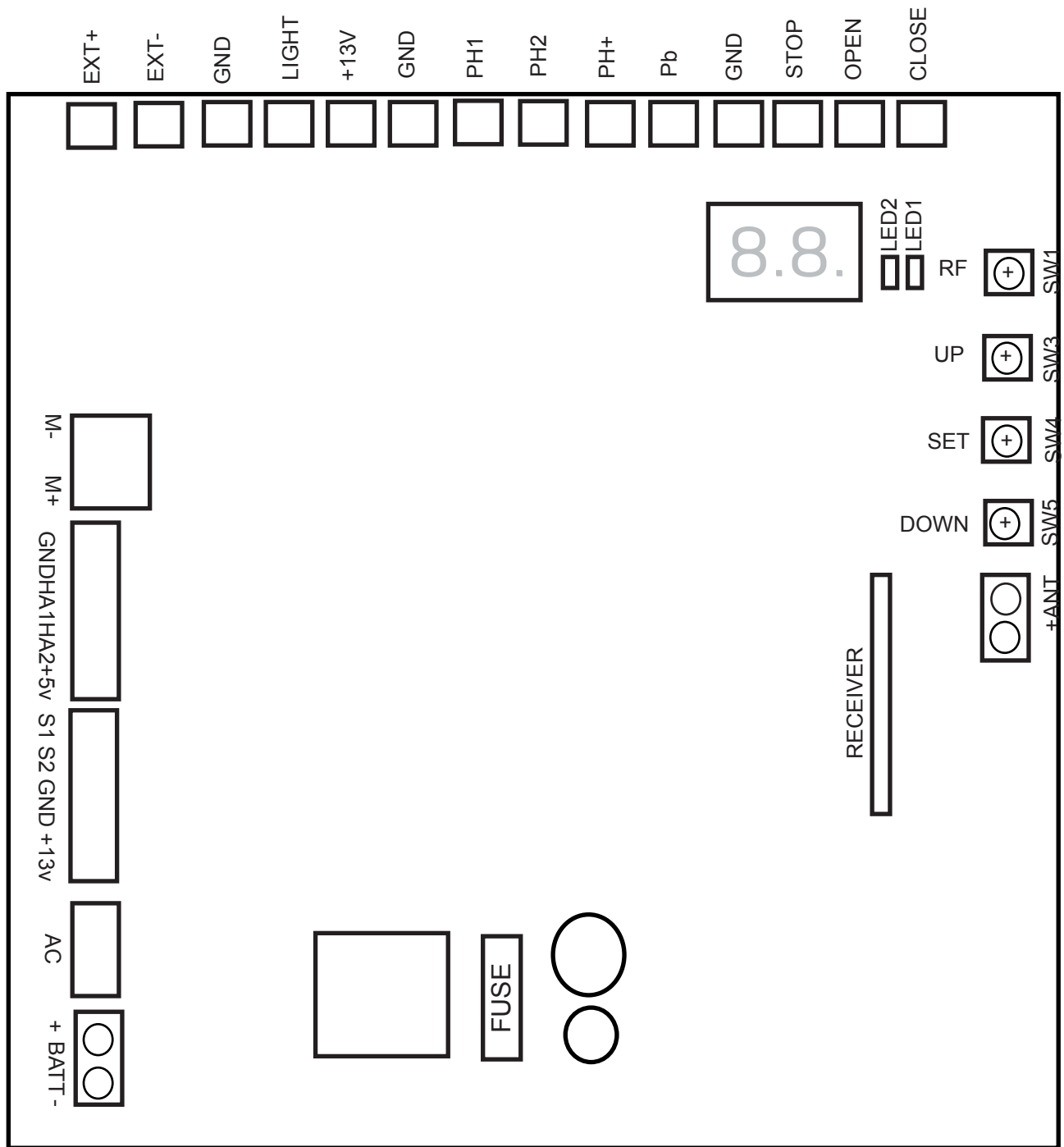

## REMOTE TUNING & ERASING

1. Remote tuning: Press the RF button for 3 seconds and the LED display will show CS. Then press the remote left button (A), the LED display will blink 3 times and stay on. After 7 seconds without any new remotes learnt, the LED will be off and the remote learning is complete - see images 1, 2, 3
2. Remote erasing: Press the RF button for 10 seconds until the LED displays CC, now all remotes have been deleted

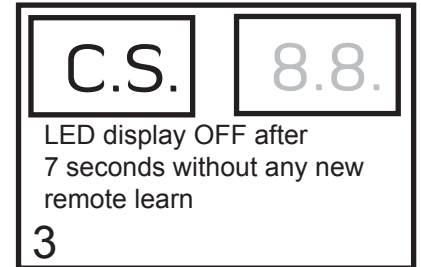
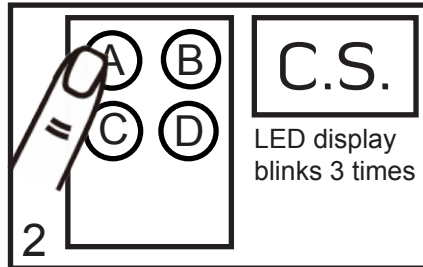
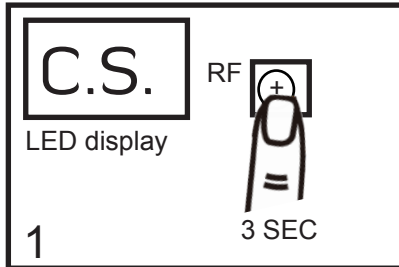

## SYSTEM LEARN

### BEFORE PROCEEDING TO THE SYSTEM LEARN THE REMOTES MUST BE TUNED TO COMPLETE THIS PROCESS

**Step 1:** Determine which way your gate slides open. Standing on the inside looking at your motor, will your gate slide open to the left or right. Default setting for the system is a gate sliding open to the left. If your gate slides open to the right you will need to adjust number 1 setting on the main control board to 12.

**Step 2:** Place your gate in the fully closed position and make sure the gear box is engaged by pushing the lever back in and that you cannot move your gate manually.

**Step 3:** Press and hold 'SET' and 'DOWN' for 3 seconds and the LED display shows 'LE' (see image 1, 2)

**Step 4:** Press left button (A) on remote one time, the LED display should show "LP" (see image 3, 4)

**Step 5:** The gate goes into auto learning, please wait for this process to complete (see image 5, 6)

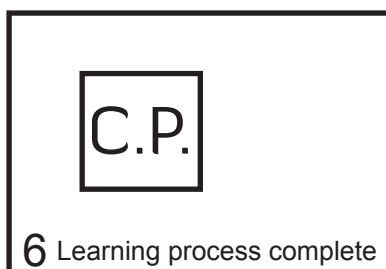
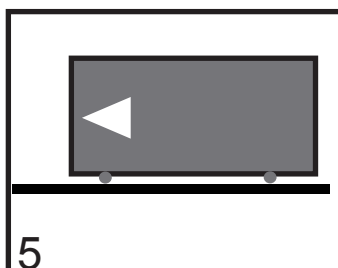
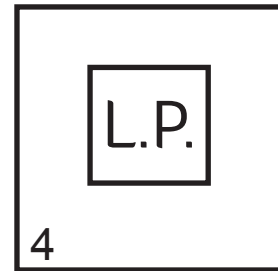
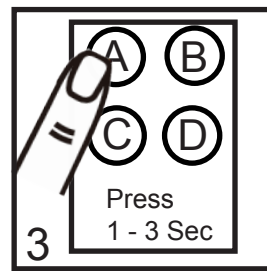
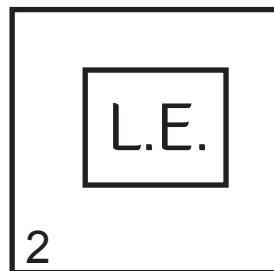
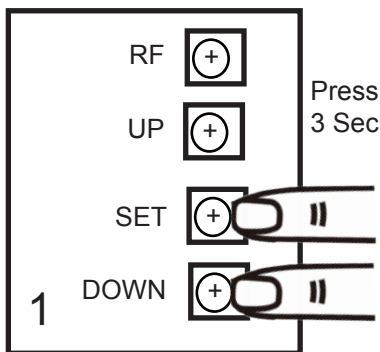

Watch Video

**VERY IMPORTANT:** Once the Learn is complete test the gate's operation to make sure it's opening and closing directions are correct. When you press the remote button to open the gate, the control board LED display will read "O.P." and when you press the remote button to close the gate, the LED display will read "C.L." If this is not reading correctly and it is reading opposite to the above then you have not set your operation direction correctly. Follow steps 1 through to 5 again and check that the direction is now correct.

## FACTORY RESET

**IF A FACTORY RESET IS REQUIRED FOR SOME REASON, FOLLOW THE BELOW INSTRUCTIONS**

It is recommended the user checks the menu functions and adjust any values back to BMGi default settings before proceeding.

Press UP and DOWN for 3 seconds and the LED will display "CL"

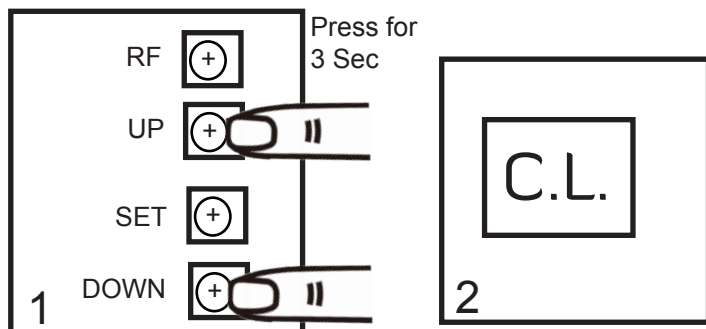

## MOTOR CURRENT AUTO-DETECTION



The LED display shows the current consumption of the motor. "0.4" During the system learning procedure, the control panel will automatically detect the current consumption from the motor and indicate the resistance level of the gate while the motor is in operation. If this reading increases instantly or stays in the high readings, please check the running of your gate such as wheels, track, rack etc.

## LED DISPLAY

-.L.	The system learning is not done
O.P.	The system is in normal operation to program, press SET button for 3 seconds, when the LED display changes from OP to 1 press UP or DOWN to change the function settings (1 to P). Then press SET to enter the sub function within each group, press UP or DOWN to select sub function and press SET for confirmation
C.P.	System learning completed
L.E.	Enter learning mode and then wait for learning instructions
L.P.	The system learning is in progress. The auto learning process of the gate moving - gate opens to the end stop and then closes to the end stop
C.L.	Reset factory setting

## AUTO CLOSE OVERRIDE

If you have auto close set, it is ideal that you also assign one of the remote buttons to 'Auto Close Override'. You will need to go into setting 'U' on the control board to set a remote button to 'Auto Close Override'. To activate 'Auto Close Override' have the gate in the closed position and press the remote button that you have assigned to the 'Auto Close Override'. The gate will start to open slow letting you know that the auto close function has been deactivated.

Reactivate the auto close by pressing the 'Auto Close Override' button on the remote. This will start the auto close count down and then the gate will close.

# HOW TO SET THE PARAMETERS

**Step 1:** Press the “SET” key for 3 seconds, the LED display will show the function code.

**Step 2:** Choosing the setting by UP and DOWN keys, after having chosen the indicated item, press the SET key and enter the setting of this function. The second digit will be shown on the right of the display, indicating the related function (refer to the below chart for details).

Use the UP and DOWN keys to choose the setting function and press the SET key to save.

## PROGRAMMABLE FUNCTION SETTINGS

LED	DEFINITION	FUNCTION	VALUE	DESCRIPTION
1	Operation Direction **Standing/looking at the motor	11	Left Opening (Default)	Gate opens to the left Gate opens to the right
		12	Right Opening	
2	Auto Closing	20	No auto Close (Default)	When function 2 is set from 21 to 28 the auto close override runs at 50% speed. However, the motor needs to ramp down to match the 6 function “Open - Ramp Down speed”, to avoid hitting the end stop
		21	5 sec	
		22	15 sec	
		23	30 sec	
		24	45 sec	
		25	60 sec	
		26	80 sec	
		27	120 sec	
		28	180 sec	
3	Safety Device Function	31	Mode 1 (Default)	Refer to page 18 for more information
		32	Mode 2	
		33	Mode 3	
4	Opening Speed	41	50% Operating speed	
		42	70% Operating speed	
		43	85% Operating speed	
		44	100% Operating speed (Default)	
5	Closing Speed	51	50% Operating speed	
		52	70% Operating speed	
		53	85% Operating speed	
		54	100% Operating speed (Default)	
6	Open - Ramp Down speed	61	20% Operating speed (Default)	Advised to maintain Default setting
		62	30% Operating speed	
		63	40% Operating speed	
		64	50% Operating speed	
7	Close - Ramp Down speed	71	20% Operating speed (Default)	Advised to maintain Default setting
		72	30% Operating speed	
		73	40% Operating speed	
		74	50% Operating speed	
8	Opening Ramp Down Distance	81	First 25% of full distance	BMGi default 81 preset in factory
		82	First 20% of full distance	
		83	First 15% of full distance (Default)	
		84	First 10% of full distance	
9	Close Ramp Down Distance	91	First 25% of full distance	BMGi default 91 preset in factory
		92	First 20% of full distance	
		93	First 15% of full distance (Default)	
		94	First 10% of full distance	

.....CONTINUED

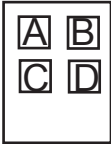
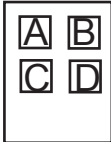
LED	DEFINITION	FUNCTION	VALUE	DESCRIPTION
A	Opening Overcurrent Setting	A1 A2 A3 A4 A5 A6 A7 A8 A9 AA	4A (Light Gate) 5A 6A 7A 8A 9A (Medium Gate) 10A (Default) 11A 12A 13A (Heavy Gate)	
C	Closing Overcurrent Setting	C1 C2 C3 C4 C5 C6 C7 C8 C9 CA	4A (Light Gate) 5A 6A 7A 8A 9A (Medium Gate) 10A (Default) 11A 12A 13A (Heavy Gate)	
E	Pedestrian Mode Travel Time	E0 E1 E2 E3 E4 E5 E6	OFF (Default) 3 Seconds (BMGi Default - preset in factory) 6 Seconds 9 Seconds 12 Seconds 15 Seconds 18 Seconds	E1 = 3 sec This is how long the gate will open for before turning off to create a pedestrian gap
F	Flashing Light	F0 F1	Motor & flashing light will operate at same time Flashing light will keep blinking for 1 min after the motor stops	
H	Overcurrent Reaction	H0 H1 H2 H3	Stop Reverse for 1 second and stop Reverse for 3 seconds and stop Revers to the end (Default)	
J	Main Remote Button 	J1 J2 J3 J4	A key (Default) B key C key D key	Function for open/stop/close
L	Pedestrian Remote Button 	L0 L1 L2 L3 L4	No Function (Default) A key B key (BMGi Default - preset in factory) C key D key	

.....CONTINUED

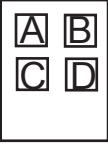
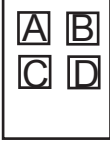
LED	DEFINITION	FUNCTION	VALUE	DESCRIPTION
P	External Device key 	P0 P1 P2 P3 P4	No Function (Default) A key B key C key D key	
U	Auto Close Override 	U0 U1 U2 U3 U4	No Function (Default) A key B key C key D key	
A.	PH1 Activation	A.0 A.1	Function OFF (Default) Function ON	<b>Photocell 1</b>
C.	PH2 Activation	C.0 C.1	Function OFF (Default) Function ON	<b>Photocell 2</b>
E.	PCB Stop Terminal Activation	E.0 E.1	Function OFF (Default) Function ON	
F.	PB Terminal Function	F.1 F.2 F.3 F.4	Open-Stop-Close-Stop (Default) Open ONLY Pedestrian Mode Fire Alarm Mode	
H.	Open Terminal Function	H.1 H.2 H.3 H.4	Open-Stop-Close-Stop (Default) Open ONLY Pedestrian Mode Fire Alarm Mode	
J.	Over Current Sensitivity	J.1 J.2 J.3 J.4 J.5 J.6 J.7 J.8 J.9 J.A	0.1 second 0.2 second 0.3 second 0.4 second 0.5 second (Default) 0.6 second 0.7 second 0.8 second 0.9 second 1 second	



### F3 Function Settings

**Logic F3-1** The reactions of the photocells when detecting obstacles

Gate Status	Photocell 2	Photocell 1
Closed	Open not allowed	No effect
Open	No effect	Reloads automatic closing time
Stop during moving	Open not allowed	Reloads automatic closing time
Closing	No effect	Open
Opening	Close	No effect

**Logic F3-2** The reaction of the photocell when detecting obstacles

Gate Status	Photocell 1
Closed	No effect
Open	Reloads automatic closing time
Stop during moving	Reloads automatic closing time
Closing	Open
Opening	No effect

**Logic F3-3** The reaction of the loop detector / photocell when detecting obstacles

Gate Status	Loop Detector	Photocell 1
Closed	Open	No effect
Open	Reloads automatic closing time	Reloads automatic closing time
Stop during moving	Open	Reloads automatic closing time
Closing	Open	Open
Opening	No effect	No effect

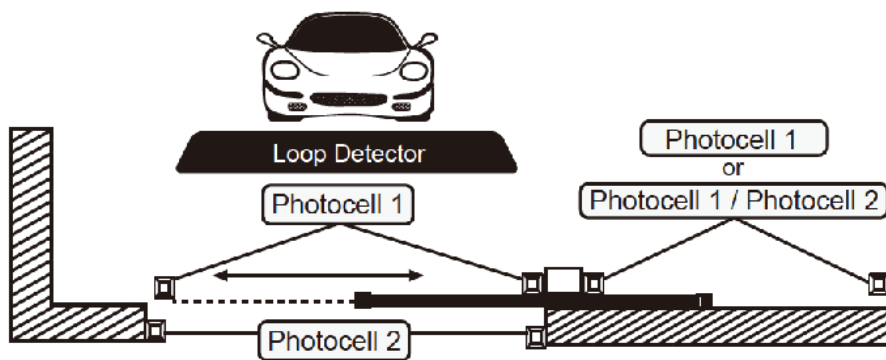

#### Testing and Checking

- \* Release the gear motor with the proper release key
- \* Make sure the gate can be moved easily manually during opening and closing phases
- \* Lock the gear motor.
- \* Using the key selector switch, push button device or the remote, test the opening, closing and stopping of the gate and make sure that the gate is in the intended direction.
- \* Check the devices one by one (photocells, visitor accessories, remotes, etc.) and confirm the motor recognizes each device

# ACCESSORY WIRING

## Wiring in your Visitor Push Button

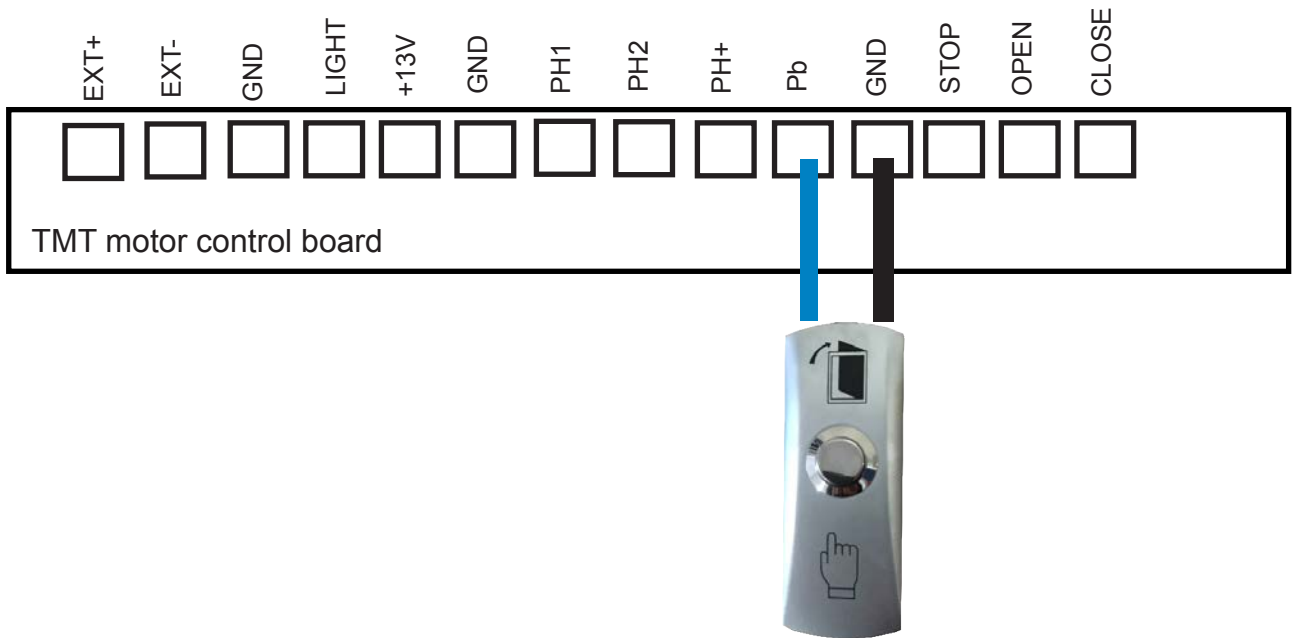

## Wiring in your Key Visitor Push Button

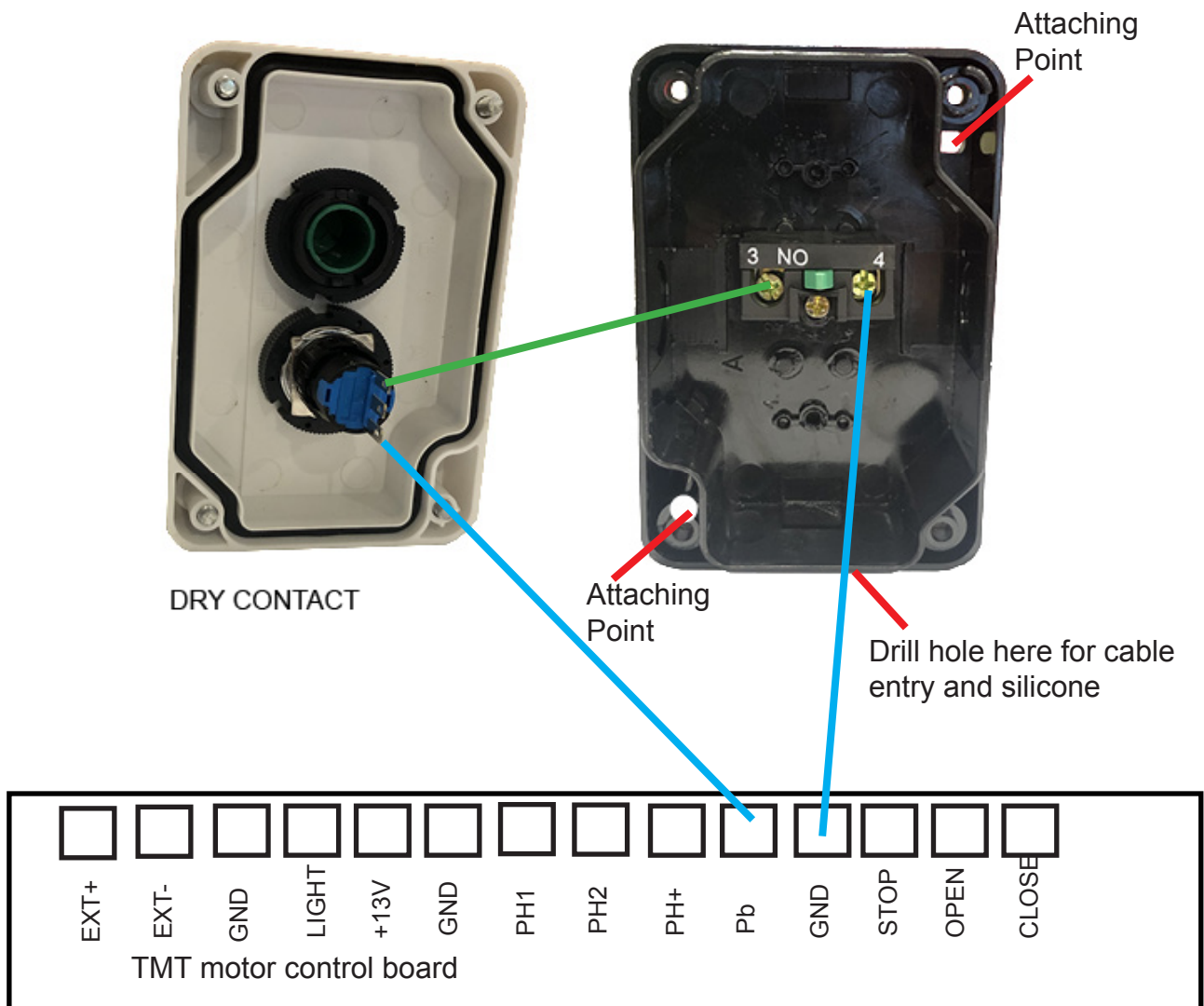

## Wiring in your Long Range Receiver

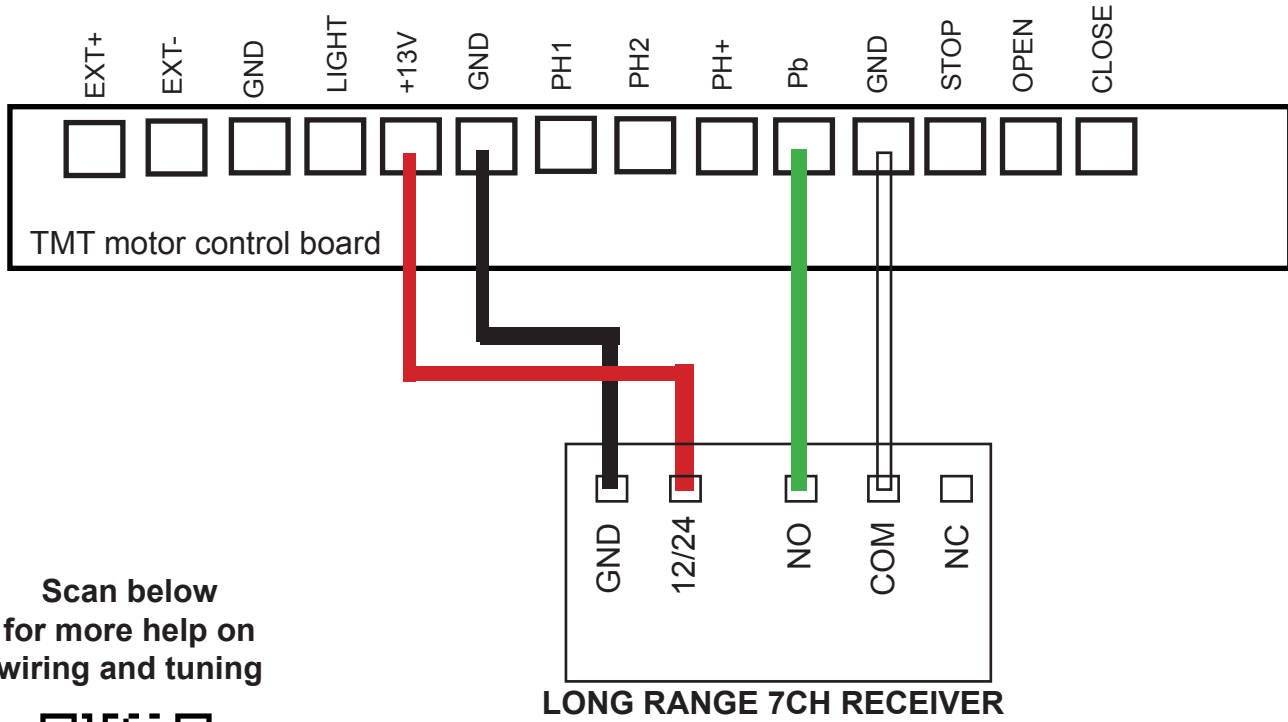

Scan below  
for more help on  
wiring and tuning



## Wiring in your KP receiver

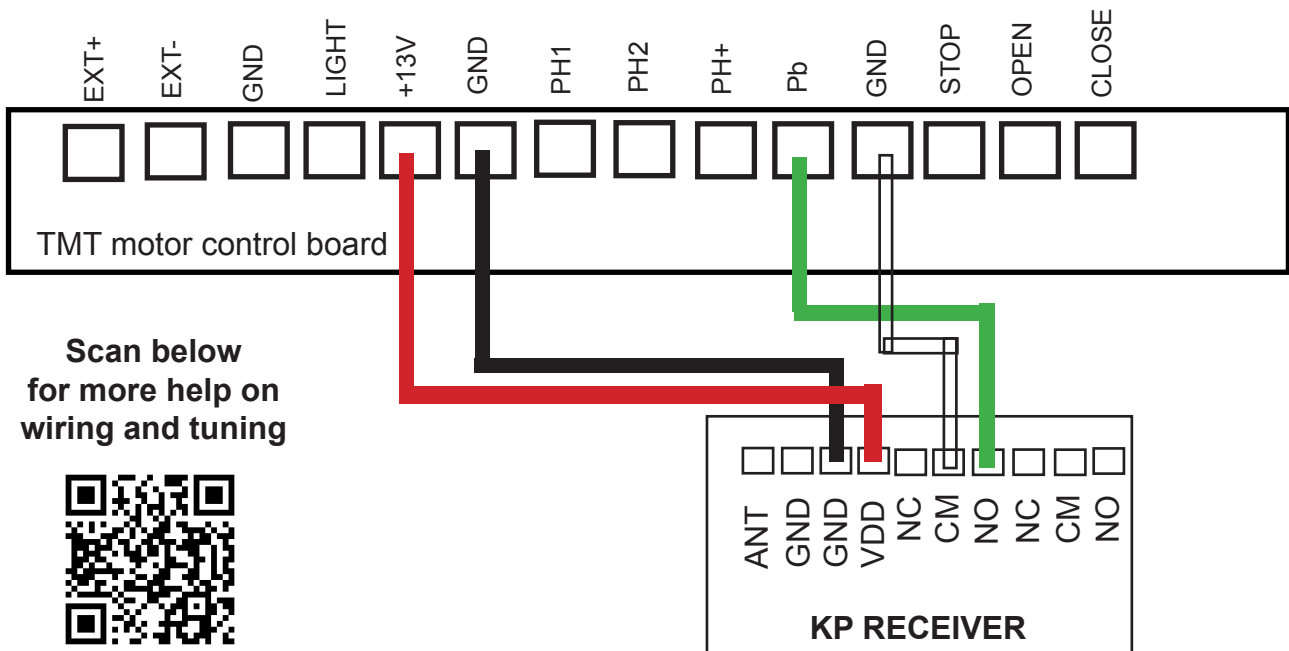

Scan below  
for more help on  
wiring and tuning



## Wiring in your Keypad

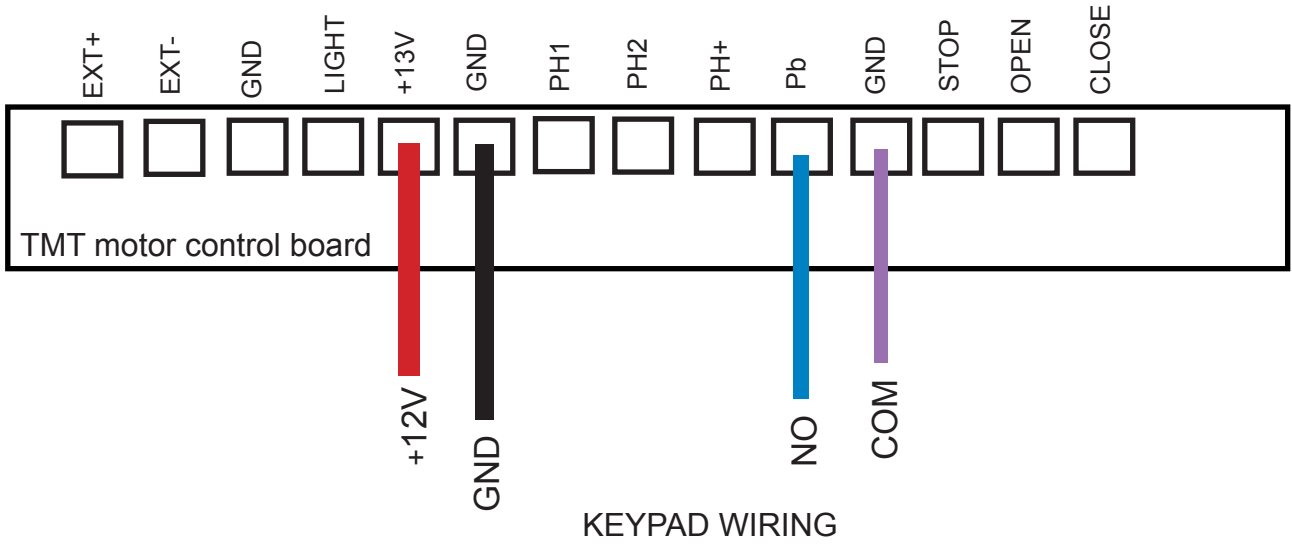

## Wiring in your GSM Gate Opener

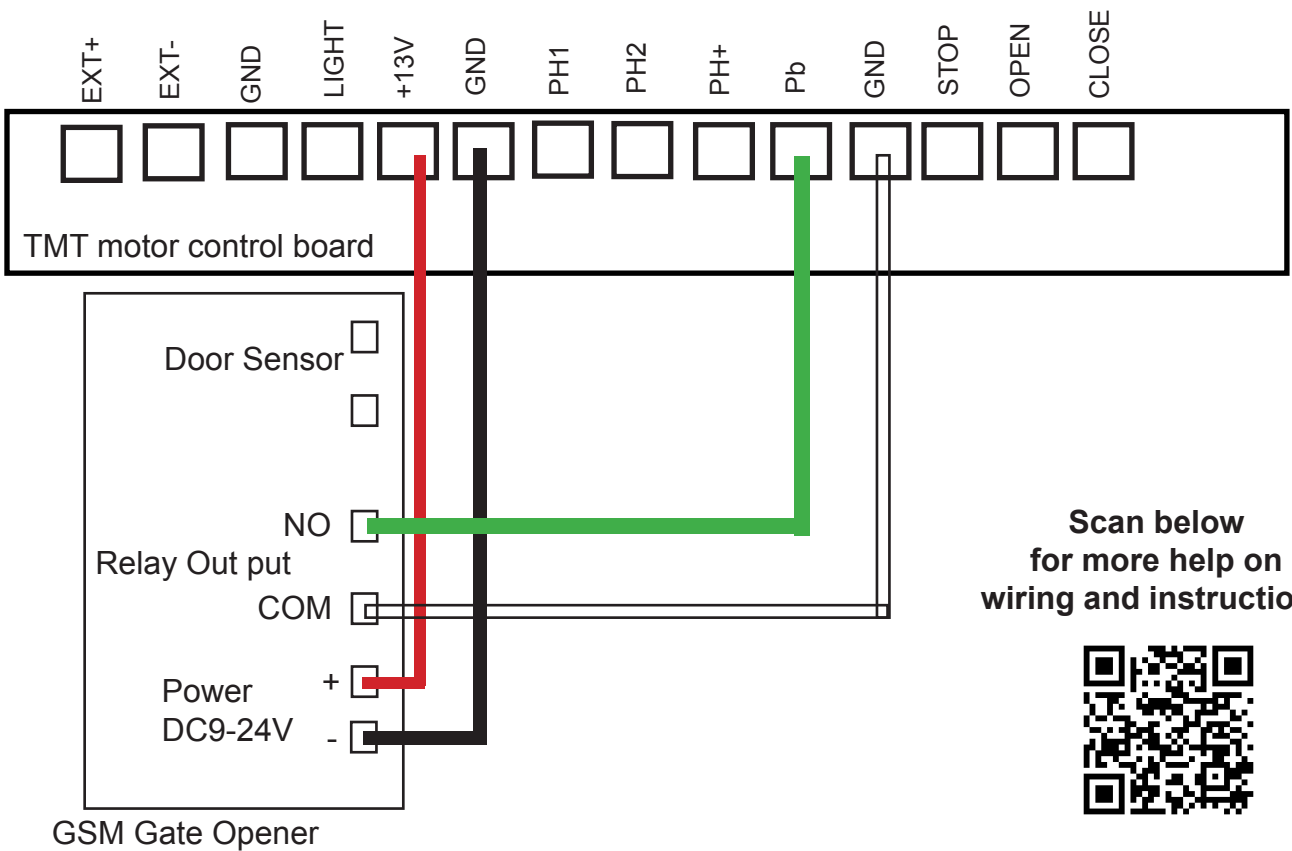

**Scan below  
for more help on  
wiring and instructions**



## Wiring in your Hard Wired Safety Beams/Photocells

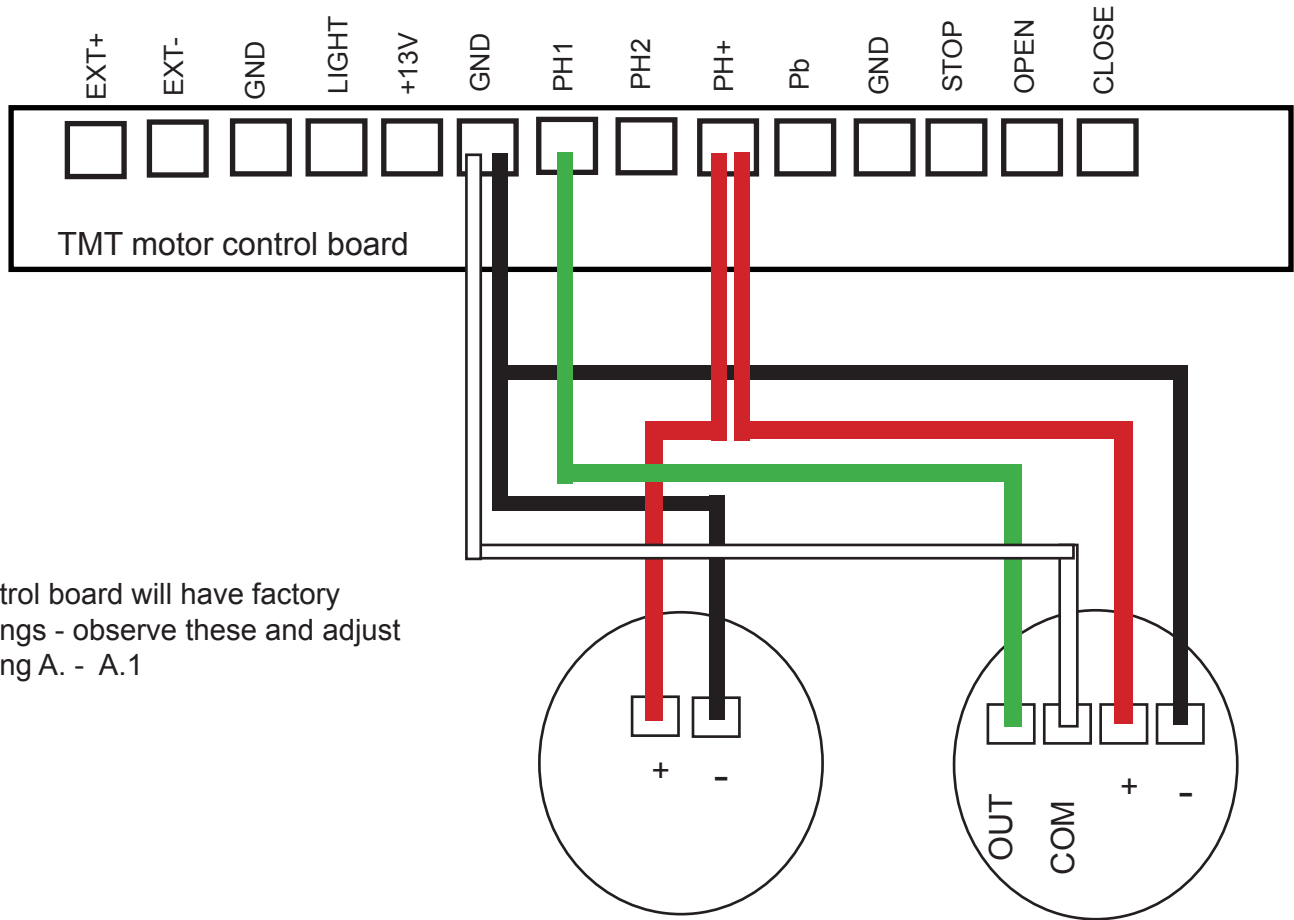

Control board will have factory settings - observe these and adjust setting A. - A.1

## Wiring in your Semi Wireless Safety Beams/Photocells

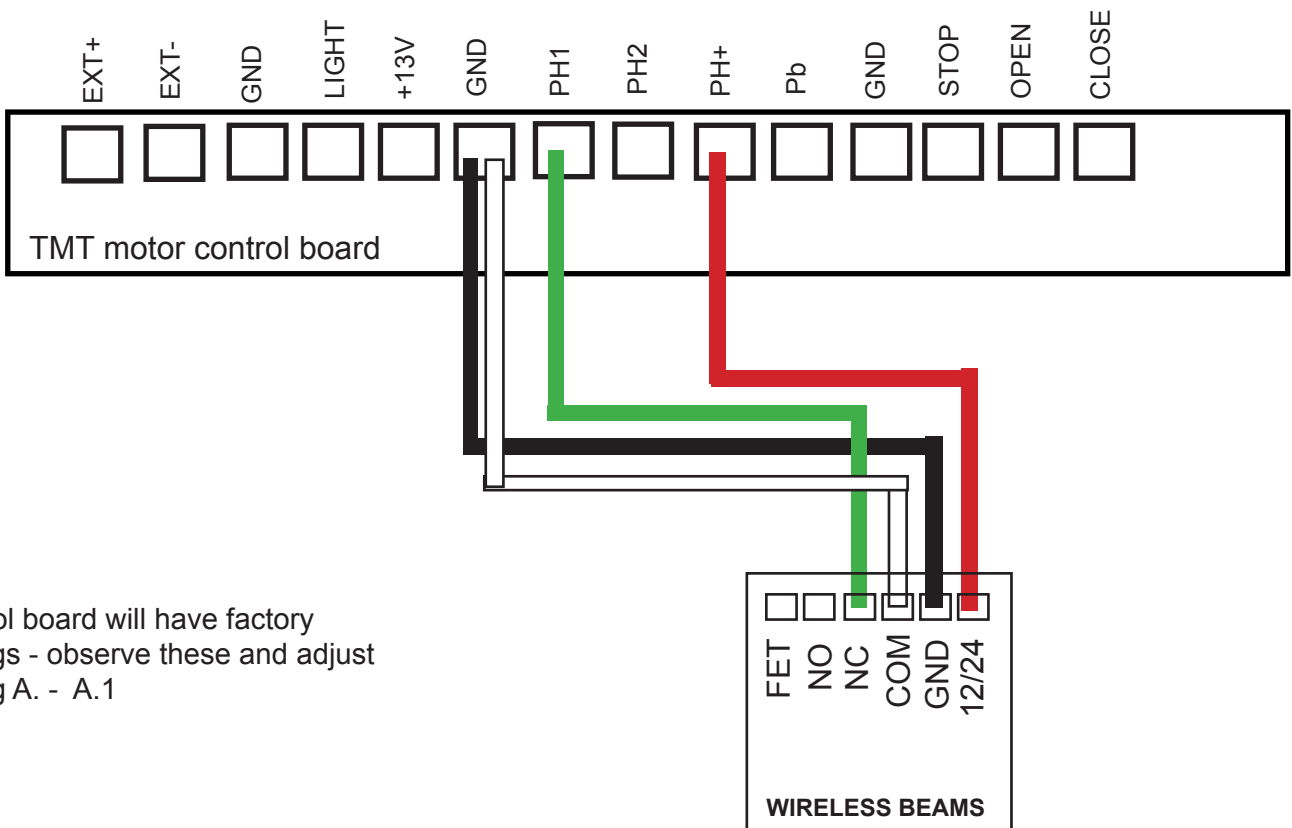

Control board will have factory settings - observe these and adjust setting A. - A.1

## Service schedule

The TMT 800LS gate operator, much like a car, will provide many years of excellent service if a service schedule is carried out at regular intervals. Follow these basic checks and do repairs in time to get the most out of your operator.

### WEEKLY

- Clear away any dirt, sand, stones or foliage collected on the gate rail.
- Clear away any branches, shrubs or grass that might interfere with the movement of the gate.

### MONTHLY

- Check for damage or cracks to the motor lid. Although the operator lid is designed for outside conditions, stones and severe hail may damage it. A cracked lid should be immediately replaced as water and dirt will damage the operator.
- Check physical end stops are secure and in place - see Site Setup page 6
- Check for insect and reptile infestations.



It is recommended that moth balls be placed inside the operator housing to discourage these infestations which can cause damage. This should be checked monthly.

### EVERY 6 MONTHS

- Place the motor into manual mode and test the gate by opening and closing slowly, take note of any tight sections you may feel.
- Check for any battery leaks if you have added a battery, these can cause damage to the wiring.
- Check that the controller and other accessories are firmly in place and are not hanging loose.
- Check that the limit brackets on the racking have not shifted.
- Check guide rollers on the gate
- Check all brackets are secure.
- Check the motor is firmly in place and cannot move.
- Check the rack for any damaged teeth.

## Warranty

### Limited 2 Year Warranty

BMG's 2 year limited warranty covers the motor and control board, it excludes any other components that might have been supplied with the operator such as a transformer or remotes. This warranty explicitly only covers the repair, components and labour carried out a BMGi, all other costs will be for the account of the purchaser.

2 year - motor and control board

1 year - internal transformer

6 months - remotes (it is expressly noted that remotes and batteries carry a six month warranty due to the nature of these products being such that they are subject to possible misuse)

This warranty does not apply if:

- \* the operator was subjected to misuse,
- \* the operator was installed contrary to the specifications provided in the manual,
- \* to any product being installed within 800mtrs of the sea or other body of water of equivalent or greater salt concentration
- \* any attempt has been made to repair the goods by any workshop and/or person not authorised to do so by BMG or
- \* if goods have been repaired using components not tested, passed or authorised by BMG

This warranty does not cover:

- \* any acts of god, including lightning, hail, water, power surge, insect damage or corrosion,
- \* consumables including but not limited to: batteries, fuses, globes, sensitivity adjustment, transmitter and receiver range
- \* the transport, or costs associated with the transport, of the defective product to a designated BMG contractor or other third party costs
- \* any other costs that may have been incurred by the purchaser or any other party or
- \* on side repairs

**Important Notice**

An auto gate system cannot prevent burglary. It is only a replacement way for the user to open the gate. Auto gate systems are generally very reliable but they may not work under all conditions and they are not a substitute for prudent security practices or life and property insurance. Your auto gate system should be installed and serviced by qualified professionals who should instruct you on the level of protection that has been provided and on the system operations.

**Note to Installers**

This warning contains vital information. As the only individual in contact with the systems user, it is your responsibility to bring each item in this warning to the attention of the users of this system.

**Systems Failures**

This system has been carefully designed to be as effective as possible. There are circumstances, however, involving fire, burglary, or other types of emergencies where it may not provide protection. Any auto gate system of any type may be compromised deliberately or may fail to operate as expected for a variety of reasons. Some but not all of these reasons may be:

**Inadequate Installation:**

A security system must be installed properly in order to provide adequate protection. Every installation should be evaluated by a security professional to ensure that everything is correct.

**Criminal knowledge:**

This system contains security features which were known to be effective at the time of manufacture. It is possible for persons with criminal intent to develop techniques which reduce the effectiveness of these features. It is important that an auto gate system be reviewed periodically to ensure that its features remain effective and that it be upgrade or replaced if it is found that it does not provide the protection expected.

**Power Failure:**

Control units require an adequate power supply for proper operation. If a device operates from batteries, it is possible for the batteries to fail. Even if the batteries have not failed, they must be charged, in good condition and installed correctly. If a device operates only by AC power, any interruption, however brief, will render that device inoperative while it does not have power. Power interruptions of any length are often accompanied by voltage fluctuations which may damage electronic equipment such as security system. After a power interruption has occurred, immediately conduct a complete system test to ensure that the system operates as intended.

**Failure of Replaceable Batteries:**

The expected battery life is a function of the device environment, usage a type. Ambient conditions such as high humidity, high or low temperatures, or large temperature fluctuations may reduce the expected battery life. A low battery will cause a low power condition in the system which will then have a problem functioning as usual. Regular testing and maintenance will keep the system in good operating condition.

**Compromise of Radio Frequency (Wireless) Devices:**

Signals may not reach the receiver under all circumstances which would include metal objects placed on or near the radio path or deliberate jamming or other inadvertent radio signal interference.

**Component Failure:**

Although every effort has been made to make this system as reliable as possible, the system may fail to function as intended due to the failure of a component.

**Inadequate Testing:**

Most problems that would prevent an auto gate system from operating as intended can be found by regular testing and maintenance. The complete system should be tested weekly and immediately after a break-in, an attempted break-in, fire, storm, earthquake, accident, or any kind of construction activity inside or outside the premises.

**PLEASE VISIT OUR WEBSITE FOR TERMS AND CONDITIONS**

**WWW.BMGI.COM.AU**

**OR SCAN THE QR CODE BELOW**

